



Conductivity sensor for hygienic applications

- Perfect for demanding applications in the hygienic industry (CIP and SIP compatible)
- Wide measuring range thanks to various options available
- Support of the most important process connections ensures specific customer requests can be implemented
- Perfectly suited to the multi-purpose transmitter/controller Type 8619

Product variants described in the data sheet may differ from the product presentation and description.

Can be combined with



Type 8619 ▶
multiCELL - Multi-channel and multi-function transmitter/controller



Type 8200 ▶
Armatures for conductivity probes (with PG 13.5 thread connection)



Type BBS-25 ▶
Clamp ferrules, clamps and gaskets - acc. DIN 32676

Type description

The 8221 hygienic conductivity probes are used to determine electrical conductivity in a wide range of pure or concentrated liquids. Due to their hygienic and robust design, these conductivity probes are suitable for use in various application sectors, including the food & beverage, pharmaceutical, biotechnology and chemical industry.

Two technologies of conductivity probes are available:

- Probes based on the 2-electrode principle are suited for measurements in liquids, especially (ultra) pure water. Contaminations affect the measurements.
- Probes based on the 4-electrode principle exclude polarisation phenomena and are not sensitive to contamination. The clever design guarantees an excellent linearity over the entire measurement range.

An integrated temperature sensor (Pt1000) is a standard feature of all versions.

The probe has to be connected to the multiCELL transmitter/controller Type 8619.

Table of contents

1. General technical data	3
1.1. 4-electrode conductivity probe.....	3
1.2. 2-electrode conductivity probe.....	4
2. Product versions	5
2.1. 4-electrode conductivity probe.....	5
2.2. 2-electrode conductivity probe.....	5
3. Approvals	6
3.1. Certificates.....	6
3.2. Pressure Equipment Directive.....	6
4. Materials	6
4.1. Chemical Resistance Chart – Bürkert resistApp.....	6
5. Dimensions	7
5.1. 4-electrode conductivity probe with VarioPin electrical connection.....	7
With 1½" clamp process connection.....	7
With 2" clamp process connection.....	7
With 2" (DN50/40) process connection adapted for GEA Tuchenhagen VARINLINE process connections	8
With PG 13.5 process connection	8
5.2. 2-electrode conductivity probe with 5 pin M12 male connector	9
With 1½" clamp process connection.....	9
With screw-on process connection	9
6. Performance specifications	10
6.1. Linearity diagram	10
6.2. Pressure temperature diagram.....	10
7. Product installation	11
7.1. Installation notes.....	11
4-electrode conductivity probe with 1½" clamp or G 1¼ process connection.....	11
4-electrode conductivity probe with PG 13.5 process connection	11
2-electrode conductivity probe with clamp, G or NPT process connection.....	12
8. Product operation	12
8.1. Measuring principle	12
9. Networking and combination with other Bürkert products	13
10. Ordering information	13
10.1. Bürkert eShop – Easy ordering and quick delivery.....	13
10.2. Bürkert product filter.....	13
10.3. Ordering chart.....	14
10.4. Ordering chart accessories.....	14

1. General technical data

1.1. 4-electrode conductivity probe

Product properties	Measuring range: 0.1 µS/cm...500 mS/cm	Measuring range: 1 µS/cm...500 mS/cm
Materials		
Please make sure the device materials are compatible with the fluid you are using. Detailed information can be found in chapter "4.1. Chemical Resistance Chart – Bürkert resist-App" on page 6.		
Electrode	Stainless steel 1.4435/316L	
Frame	PEEK (conform to FDA - 21CFR 177.2415) Stainless steel 1.4435/316L (not for PG 13.5 connection)	
Seal	EPDM (conform to FDA - 21CFR177.2600)	
Measuring range	0.1 µS/cm...500 mS/cm	1 µS/cm...500 mS/cm
Temperature sensor	Pt1000	
Electrical data		
Electrical connections	VarioPin (VP 6.0)	
Performance data		
Technology	4-electrode	
Linearity ^{1.)} (relative)	± 0.5...5 %	
Cell constant ^{2.)}	0.147 cm ⁻¹	0.360 cm ⁻¹
Surface quality	0.4 µm, electro-polished	
Medium data		
Fluid temperature	-20...+135 °C (-4...+275 °F)	-20...+150 °C (-4...+302 °F)
Fluid pressure	Max. 6 bar (87.06 PSI)	Max. 20 bar (290.2 PSI) for -20...+135 °C (-4...+275 °F) and max. 10 bar (145.1 PSI) at 150 °C (302 °F)
Detailed information on the fluid pressure can be found in chapter "6.2. Pressure temperature diagram" on page 10.		
Approvals and Certificates		
Certificates		
<ul style="list-style-type: none"> • FDA declaration of conformity (only for version with PEEK frame and EPDM seal) • ECR1935/2004 declaration • USP class VI declaration • Inspection certificate 3.1 • 2-point calibration certificate (on request) • Test report for surface finish (on request) 		
Standards		
Protection class according to IEC/EN 60529	IP67, with connected device, inserted and screwed VarioPin plug	
Directives		
CE directives	The applied standards, which verify conformity with the EU Directives, can be found on the EU Type Examination Certificate and/or the EU Declaration of conformity (if applicable)	
Pressure equipment directives	Complying with Article 4, Paragraph 1 of 2014/68/EU directive Detailed information on the pressure equipment directive can be found in chapter "3.2. Pressure Equipment Directive" on page 6.	
Product connections		
Process connection	In short or long immersion depths: 1½" clamp connection G 1¼ process connection (on request)	2" clamp connection 2" (DN50/40) connection adapted for GEA Tuchenhagen VARINLINE PG 13.5 connection
Environment and installation		
Ambient temperature	Storage: +4...+40 °C (+39.2...+104 °F)	

1.) An uncertainty of ± 5 % arises when using only one single cell constant over the full range. ± 0.5 % measurement deviations can be achieved when calibration is performed in a conductivity range close to that of the used solution.

2.) Nominal cell constant. Every product is measured according to a Bürkert standard procedure and the individual cell constant measured is reported in the calibration report, delivered with the product. The cell constant can be influenced by the assembly situation.

1.2. 2-electrode conductivity probe

Product properties	Measuring range 0.05...20 µS/cm version	Measuring range 1...200 µS/cm version
Materials		
	Please make sure the device materials are compatible with the fluid you are using. Detailed information can be found in chapter "4.1. Chemical Resistance Chart – Bürkert resist-App" on page 6.	
Electrode	Stainless steel 316L	
Frame	PEEK (conform to FDA - 21CFR 177.2415) Stainless steel 316L	
Seal	EPDM (conform to FDA - 21CFR 177.2600)	
Measuring range	0.05...20 µS/cm	1...200 µS/cm
Temperature sensor	Pt1000	
Response time (t ₉₀)	60 s	100 s
Electrical data		
Electrical connections	5 pin M12 male fixed connector	
Performance data		
Technology	2-electrode	
Linearity ^{1.)} (relative)	±0.5...5 %	
Cell constant ^{2.)}	0.01 cm ⁻¹	0.1 cm ⁻¹
Surface quality	0.4 µm, electropolished	
Medium data		
Fluid temperature	-20...+150 °C (-4...+302 °F)	
Fluid pressure	PN16 Detailed information on the fluid pressure can be found in chapter "6.2. Pressure temperature diagram" on page 10.	
Approvals and Certificates		
Certificates		
	<ul style="list-style-type: none"> FDA declaration of conformity (only for version with stainless steel and PEEK frame and EPDM seal) Inspection certificate 3.1 2-point calibration certificate (on request) Test report for surface finish (on request) 	
Standards		
Protection class according to IEC/EN 60529	IP65, with connected device, inserted and screwed M12 female cable plug	
Directives		
CE directives	The applied standards, which verify conformity with the EU Directives, can be found on the EU Type Examination Certificate and/or the EU Declaration of conformity (if applicable)	
Pressure equipment directives	Complying with Article 4, Paragraph 1 of 2014/68/EU directive Detailed information on the pressure equipment directive can be found in chapter "3.2. Pressure Equipment Directive" on page 6.	
Product connections		
Process connection	1½" clamp connection G 1 connection G ¾ connection NPT ¾ connection	
Environment and installation		
Ambient temperature	Operation: -20...+150 °C Storage: -10...+60 °C	

1.) An uncertainty of ±5 % arises when using only one single cell constant over the full range. 0.5 % measurement deviations can be achieved when calibration is performed in a conductivity range close to that of the used solution.

2.) Nominal cell constant. Every product is measured according to a Bürkert standard procedure. The individual cell constant measured is reported in the calibration report, delivered with the product and on the label of the product. The cell constant can be influenced by the assembly situation.

2. Product versions

2.1. 4-electrode conductivity probe

Probes based on the 4-electrode principle are available in two electrode architectures:



The four active electrodes are positioned laterally on the periphery of the frame.

Product details	
Measuring range	0.1 $\mu\text{S}/\text{cm}$...500 mS/cm
Cell constant	0.147 cm^{-1}

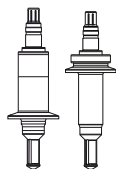

The four active electrodes are positioned at the base of the frame. Two are flat, and the other two are conical.

Product details	
Measuring range	1 $\mu\text{S}/\text{cm}$...500 mS/cm
Cell constant	0.360 cm^{-1}

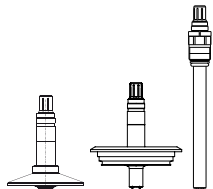

2.2. 2-electrode conductivity probe

Probes based on the 2-electrode principle are available in two electrode architectures:



The hole is located 19 mm from the base of the frame. The electrode spacing is short and the inner electrode has a large cross-section area.

Product details	
Measuring range	0.05...20 $\mu\text{S}/\text{cm}$
Cell constant	0.01 cm^{-1}

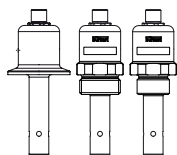

The hole is located 11 mm from the base of the frame. The electrode spacing is large and the inner electrode has a small cross-section area.

Product details	
Measuring range	1...200 $\mu\text{S}/\text{cm}$
Cell constant	0.1 cm^{-1}

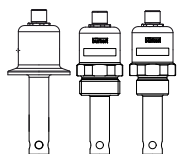

3. Approvals

3.1. Certificates

Certificates	Description
	FDA The versions with the housing made of PEEK materials and the seal made of EPDM materials comply in their composition with the Code of Federal Regulations published by the FDA (Food and Drug Administration, USA).
	EC-Regulation 1935/2004/EC The versions with the housing made of PEEK materials and the seal made of EPDM materials are suitable in their composition for use with foodstuffs and beverages (according to EC Regulation 1935/2004/EC).
	USP Class VI The versions with the housing made of PEEK materials and the seal made of EPDM materials are approved according to USP Class VI.

3.2. Pressure Equipment Directive

The device conforms to Article 4, Paragraph 1 of the Pressure Equipment Directive 2014/68/EU under the following conditions:

- Device used on a pipe (PS = maximum admissible pressure; DN = nominal diameter of the pipe).

Note:

The data in the table is independent of the chemical compatibility of the material and the fluid.

Type of fluid	Conditions
Fluid group 1, Article 4, Paragraph 1.c.i	DN ≤ 25
Fluid group 2, Article 4, Paragraph 1.c.i	DN ≤ 32 or PS*DN ≤ 1000
Fluid group 1, Article 4, Paragraph 1.c.ii	DN ≤ 25 or PS*DN ≤ 2000
Fluid group 2, Article 4, Paragraph 1.c.ii	DN ≤ 200 or PS ≤ 10 or PS*DN ≤ 5000

- Device used on a vessel (PS = maximum admissible pressure).

Note:

The data in the table is independent of the chemical compatibility of the material and the fluid.

Type of fluid	Conditions
Fluid group 1, Article 4, Paragraph 1.a.i	PS ≤ 200 bar
Fluid group 2, Article 4, Paragraph 1.a.i	PS ≤ 1000 bar
Fluid group 1, Article 4, Paragraph 1.a.ii	PS ≤ 500 bar
Fluid group 2, Article 4, Paragraph 1.a.ii	PS ≤ 1000 bar

4. Materials

4.1. Chemical Resistance Chart – Bürkert resistApp

Bürkert resistApp – Chemical Resistance Chart

You want to ensure the reliability and durability of the materials in your individual application case? Verify your combination of media and materials on our website or in our resistApp.

Start Chemical Resistance Check

DTS 1000096134 EN Version: N Status: RL (released | freigegeben | validé) printed: 04.04.2019

5. Dimensions

5.1. 4-electrode conductivity probe with VarioPin electrical connection

With 1½" clamp process connection

Note:

Specifications in mm

Short insertion version

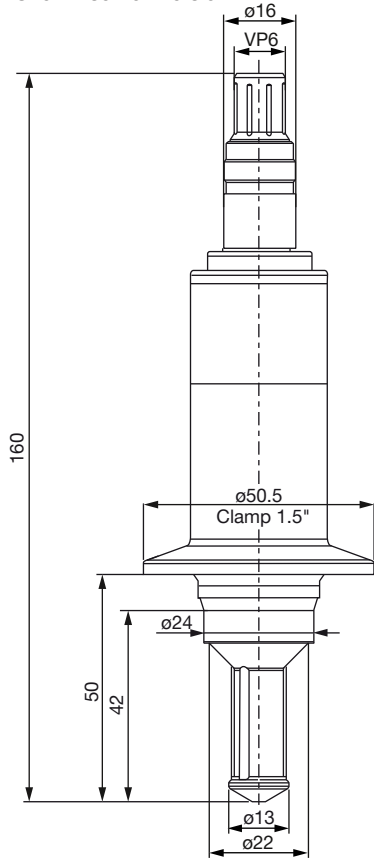

Long insertion version

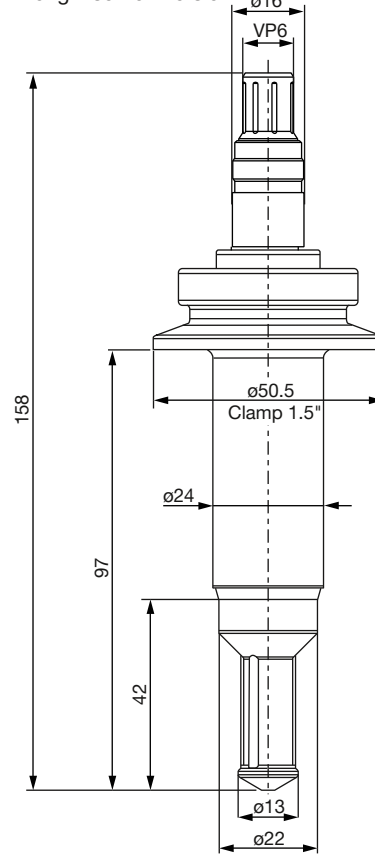

With 2" clamp process connection

Note:

Specifications in mm

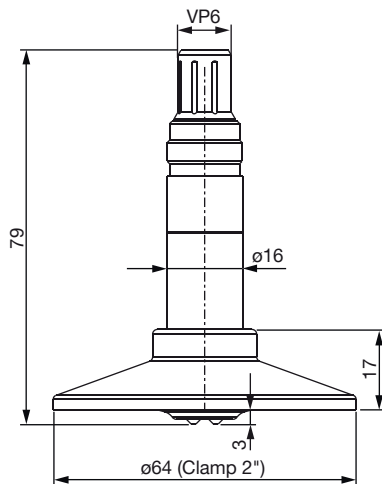

With 2" (DN50/40) process connection adapted for GEA Tuchenhagen VARINLINE process connections

Note:

Specifications in mm

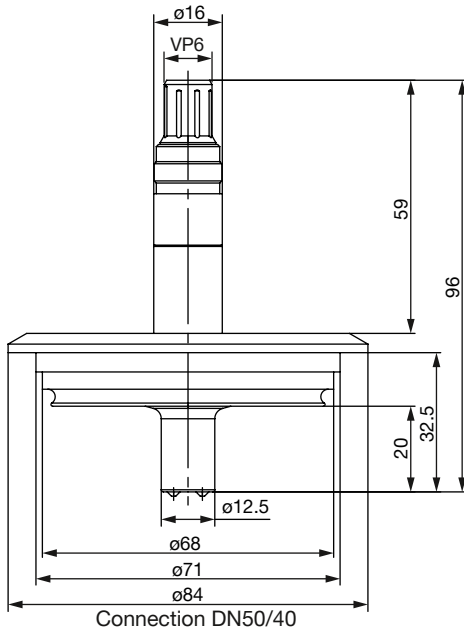

With PG 13.5 process connection

Note:

Specifications in mm

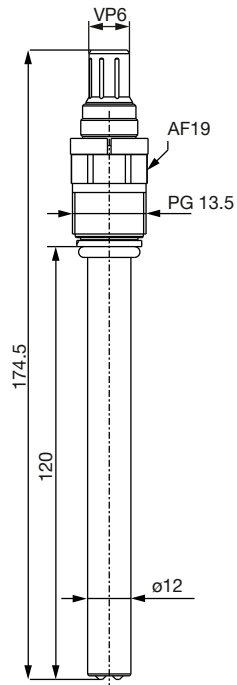

5.2. 2-electrode conductivity probe with 5 pin M12 male connector

With 1½" clamp process connection

Note:

Specifications in mm

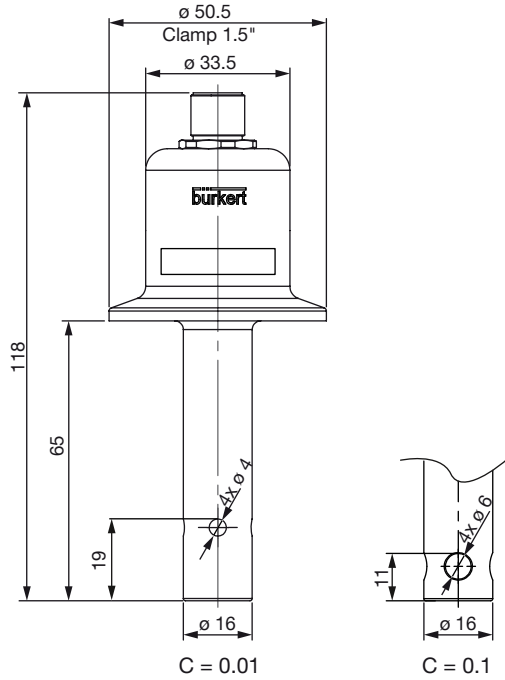

With screw-on process connection

Note:

Specifications in mm

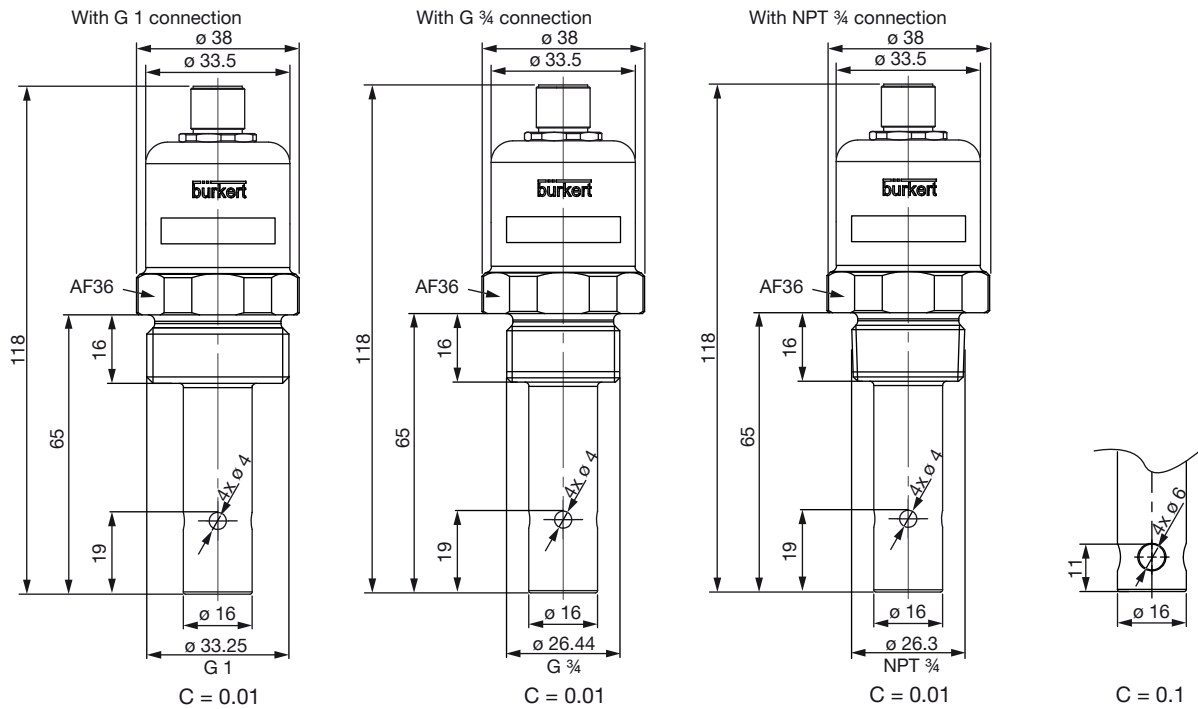

DTS 1000096134 EN Version: N Status: RL (released | freigegeben | validé) printed: 04.04.2019

6. Performance specifications

6.1. Linearity diagram

Note:

The following table applies exclusively to the conductivity probes which are constructed according to the 4-electrode principle.

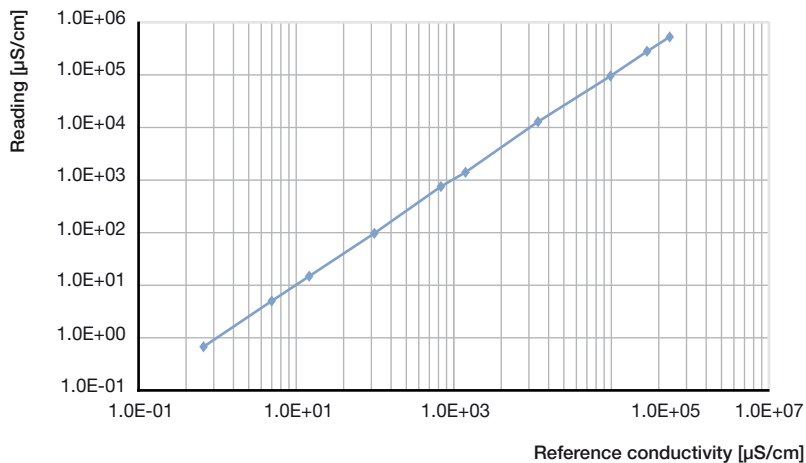

6.2. Pressure temperature diagram

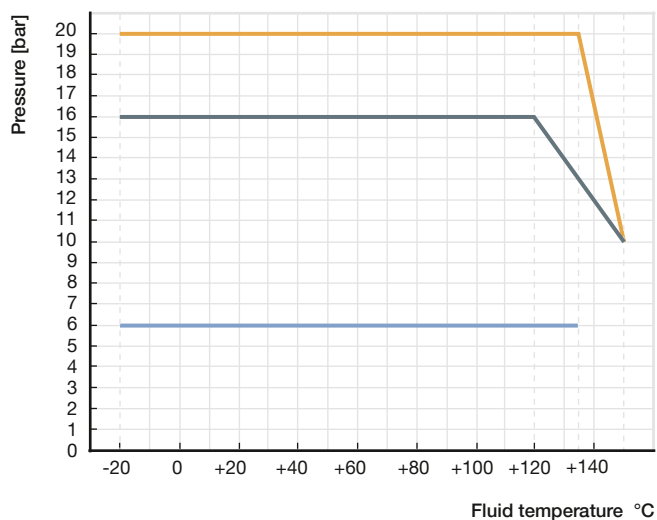

Application range for conductivity probe

- 2 electrodes, 1½" clamp connection, G 1, G ¾ or NPT ¾ connection version with M12 connector
- 4 electrodes, G 1¼ and 1½" clamp connection (short/long)
- 4 electrodes, 2" clamp connection, 2" (DN50/40) adapted for GEA Tuchenhagen VARINLINE devices and PG 13.5 connection

7. Product installation

7.1. Installation notes

4-electrode conductivity probe with 1½" clamp or G 1¼ process connection

Note:

- The process connection must be sufficiently clean.
- The conductivity probe should be installed following the instructions mentioned below.

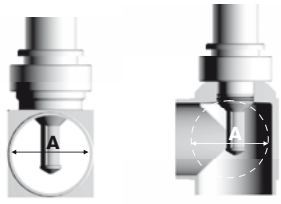
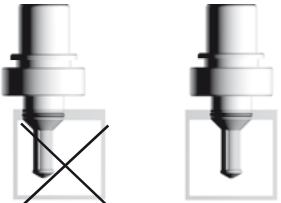
Installation example	Description
 <p>A: ø 60 mm min</p>	<p>The cell constant and the linearity of the probe can vary with the fitting situation.</p> <ul style="list-style-type: none"> • A symmetrical setup is recommended. • Leave a minimum space of 60 mm minimum diameter. • Partitions made of non-conductive material should preferably be used.
	<p>A symmetrical setup is recommended in order to ensure a high linearity.</p> <ul style="list-style-type: none"> • To achieve high precision the cell constant should be calibrated in the final setup. • Make sure that all the 4 electrodes are completely and continuously immersed in the measuring sample.

4-electrode conductivity probe with PG 13.5 process connection

Note:

- To install the conductivity probe in a T-fitting or in a pipe, a probe holder Type 8200 has to be used.
- Around the tip of the electrode there should be a space of 10 mm.

See **data sheet Type 8200** ▶ for more information.

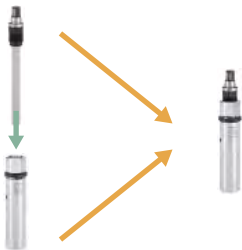
Installation example	
	<p>The conductivity probe PG 13.5 is installed in a hygienic direct welded probe holder Type 8200 without adapter.</p>
	<p>The conductivity probe PG 13.5 is installed in a hygienic direct welded probe holder Type 8200 with adapter.</p>

2-electrode conductivity probe with clamp, G or NPT process connection

Note:

- Mount the probe in a stainless steel 1½" T fitting or threaded port as shown below, taking into account the entire length of the thread and the depth of the insertion of the probe.
- The drawing shows the assembly with a process clamp connection, but this also applies to a G or NPT process connection

Installation examples	Description
<div style="display: flex; justify-content: space-around;"> <div style="text-align: center;"> <p>Probe with C = 0.01</p> </div> <div style="text-align: center;"> <p>Probe with C = 0.1</p> </div> </div>	<ul style="list-style-type: none"> • Align the probe hole as closely as possible with the centre of T fitting outlet. • Make sure that the line is thoroughly flushed of its air during the filling

8. Product operation

8.1. Measuring principle

Conductivity is defined by the property of a solution to conduct electrical current. The charge carriers are ions (e.g. dissolved salts or acids).

In the simplest case the measurement cell consists of two metal electrodes which are set at a fixed distance apart and with a known specified surface. An AC voltage supplied from the connected transmitter/controller Type 8619 is applied to the electrodes. The measured current is a direct function of the quantity of ions contained in the solution, and with help of Ohm's law the conductivity is calculated.

The 4-electrode probe consists of two current and two voltage electrodes. Between the two current electrodes there is a constant electric current. With the two voltage electrodes a voltage drop is measured across the sample. The voltage drop depends on the conductivity of the sample. As a result of this measurement principle, 4 electrode sensors have a much broader linear measurement range, are insensitive to contamination and polarization effects by adjusting the frequency of the AC voltage.

There are countless types of conductivity probes whose measurement values vary by a great margin - depending on the electrode assembly. To compensate for the geometry of the conductivity cell a cell constant is used: Conductivity [S/cm] = Measurement [S] x Cell constant [1/cm].

The cell constant is either known or it is determined by means of conductivity standards, and has to be entered into the transmitter prior to measurement.

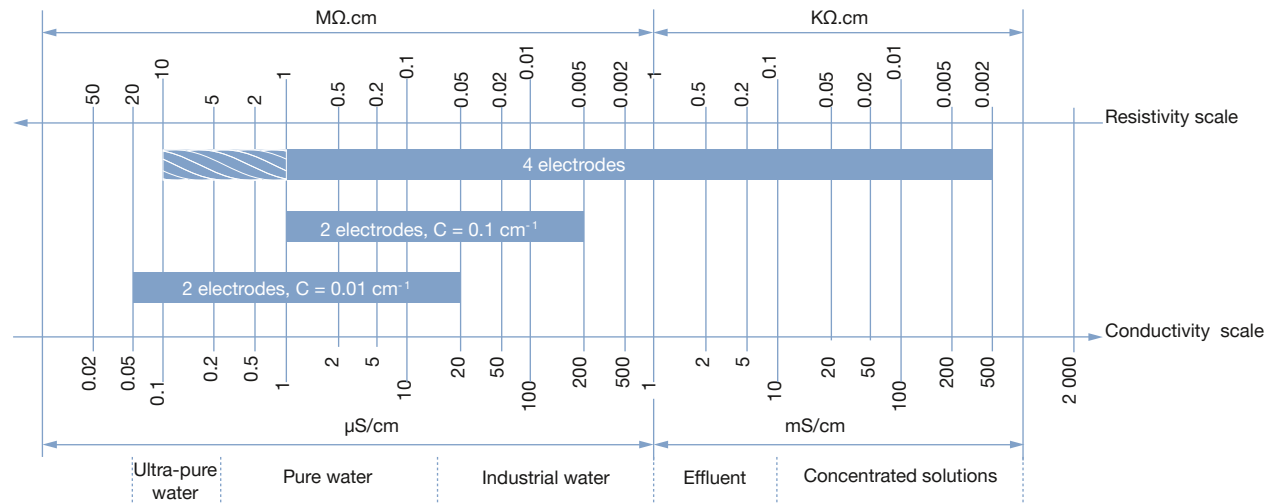

9. Networking and combination with other Bürkert products

Example:

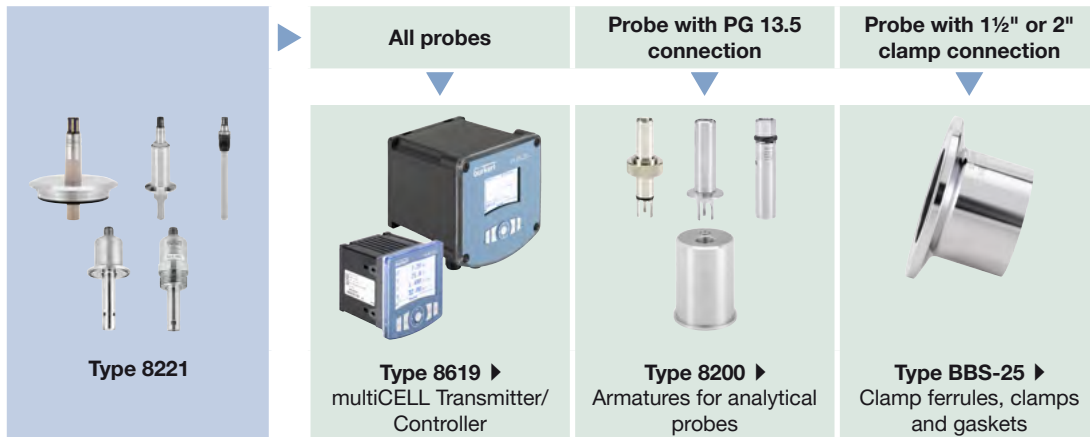

10. Ordering information

10.1. Bürkert eShop – Easy ordering and quick delivery



Bürkert eShop – Easy ordering and fast delivery

You want to find your desired Bürkert product or spare part quickly and order directly? Our online shop is available for you 24/7. Sign up and enjoy all the benefits.

[Order online now](#)

10.2. Bürkert product filter

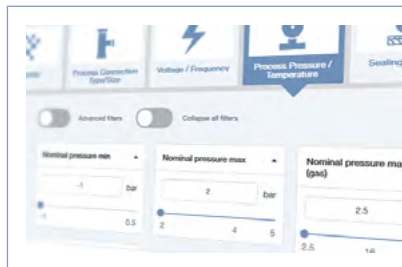













Bürkert product filter – Get quickly to the right product

You want to select products comfortably based on your technical requirements? Use the Bürkert product filter and find suitable articles for your application quickly and easily.

[Try out our product filter](#)

10.3. Ordering chart



















Cell constant [cm ⁻¹]	Measuring range [μS/cm]	Process connection	Probe version	Certifications			Article no.
				FDA	ECR1935/2004	USP class VI	
Conductivity probe 4-electrode							
0.147	0.1...500 000	1½" clamp	Short	Yes	Yes	Yes	562420 
			Long	Yes	Yes	Yes	564064 
0.360	1...500 000	2" clamp	-	Yes	Yes	Yes	559120 
		2" (D"50/40) adapted for GEA Tuchenhagen VARINLINE	-	Yes	Yes	Yes	563269 
		PG 13.5	-	Yes	Yes	Yes	563186 
Conductivity probe 2-electrode							
0.01	0.05...20	1½" clamp	-	Yes	No	No	568818 
		G 1	-	Yes	No	No	569644 
		G ¾	-	Yes	No	No	570452 
		NPT ¾	-	Yes	No	No	570454 
0.1	1...200	1½" clamp	-	Yes	No	No	569643 
		G 1	-	Yes	No	No	569645 
		G ¾	-	Yes	No	No	570453 
		NPT ¾	-	Yes	No	No	570455 

Further versions on request



Process connection
Others...e.g. G 1¼

10.4. Ordering chart accessories

Description	Article no.
Buffer solution, 5 μS/cm conductivity standard, ± 1 % accuracy, 300 ml	440015 
Buffer solution, 15 μS/cm conductivity standard, ± 5 % accuracy, 300 ml	440016 
Buffer solution, 100 μS/cm conductivity standard, ± 3 % accuracy, 300 ml	440017 
Buffer solution, 706 μS/cm conductivity standard, ± 2 % accuracy, 300 ml	440018 
Buffer solution, 1413 μS/cm conductivity standard, ± 1 % accuracy, 300 ml	440019 
Buffer solution, 100 mS/cm conductivity standard, ± 1 % accuracy, 300 ml	440020 
Connection cable VarioPin (VP 6.0) female connector, 3 meters	554855 
Connection cable VarioPin (VP 6.0) female connector, 5 meters	554856 
Connection cable VarioPin (VP 6.0) female connector, 10 meters	554857 
5 pin M12 female straight cable plug with plastic threaded locking ring, to be wired	917116 
5 pin M12 female straight cable plug moulded on cable (2 m, shielded)	438680 
5 pin M12 female straight cable plug moulded on cable (5 m, shielded)	560365 
5 pin M12 female straight cable plug moulded on cable (10 m, shielded)	563108 
EPDM sealing for conductivity sensor with G ¾ screw-on process connection	561955 
EPDM sealing for conductivity sensor with 1½" clamp process connection	730277 
FKM sealing for conductivity sensor with 1½" clamp process connection	730285 
EPDM sealing for conductivity sensor with 2" clamp process connection	730289 
FKM sealing for conductivity sensor with 2" clamp process connection	730299 

Bürkert – Close to You

For up-to-date addresses
please visit us at
www.burkert.com

DTS 1000096134 EN Version: N Status: RL (released | freigegeben | validé) printed: 04.04.2019

